

# CQD20LB



## LI-ION REACH TRUCK 2.0T

2000 kg 12000 mm 48 V Li-Ion



The CQD20LB series is ideal for high-density warehouses, logistics hubs, and distribution centers. Its optimized mast ensures stability even at full lift height, while proportional lifting provides gentle and accurate handling of heavy or fragile goods. With compact dimensions and tight turning capability, it is well-suited for space-restricted environments. Optional features such as cold storage adaptation, safety warning systems, and telematics make the CQD20LB a versatile choice across industries.

SPECIFICATION	REF	UNIT	VALUE
Manufacturer			CQD20LB
Model designation			CQD20LB
Battery voltage		V	48
Rated capacity	Q	kg	2000
Load centre distance	c	mm	600
Service weight		kg	3940
Lift	h <sub>3</sub>	mm	9500
Height, mast extended	h <sub>4</sub>	mm	10560
Overall length	l1	mm	244
Overall width	b1/b <sub>2</sub>	mm	3
Length to face of forks	l2	mm	127
Fork dimensions	s/e/l	mm	40/120/1070
Turning radius	Wa	mm	1370
Drive			Electric
Operator type			Seated
Load distance, centre of drive axle to fork	x	mm	399

# Features

## Lithium technology for great effectiveness

CQD20LB adopts 48V Li-ion battery as standard and it features zero battery maintenance and opportunity charging during breaks. This makes CQD20LB a flexible and cost-effective tool to store and retrieve pallets in multi working shifts. Plus, the charging port is external for easy charging and protected by a cover from water and dust ingress for charging safety.

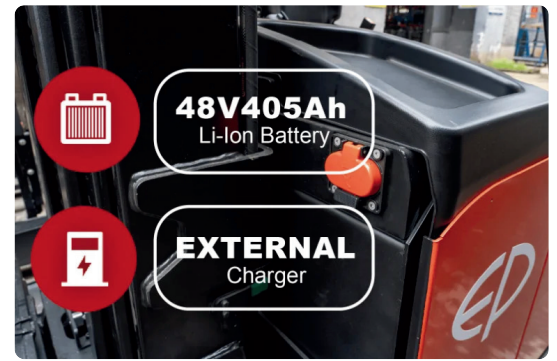

## Improved performance for productivity boost

The CQD20LB offers a greater reach distance of 610mm for effortless stacking and retrieving. The lifting and lowering speeds are also improved to reduce your cycle times and elevate your working efficiency.

## Complete configurations for easy operation

CQD20LB is of tremendous help to the operator with full-color display, electric steering with damping, joystick system as well as proportional hydraulic system, which the operator can take advantage of to handle loads more easily and precisely.



## Enhanced mast with better visibility and safety

CQD20LB's mast enables an unimpeded view of raised loads since the cylinders are moved to the side, and the enhanced mast is also vibration-free. This makes it ideal for safe operation at heights up to 9.5m, with nominal capacity performance up to 6.5m.

## Easy maintenance

The seat can be easily turned sideways, providing a quick access to internal components for daily maintenance and repair.



## Spacious operation space

CQD20LB offers spacious legroom and a suspension seat to fulfill the ergonomic needs and ensure effective operation.

## VDI Chart

	SPECIFICATION	REF	UNIT	VALUE
1.1	Manufacturer			CQD20LB
1.2	Model designation			CQD20LB
1.3	Drive			Electric
1.4	Operator type			Seated
1.5	Rated capacity	Q	kg	2000
1.6	Load centre distance	c	mm	600
1.8	Load distance, centre of drive axle to fork	x	mm	399
1.9	Wheelbase	y	mm	1515
2.1	Service weight		kg	3940
2.2	Axle loading, laden front/rear		kg	635/5340
2.3	Axle loading, unladen front/rear		kg	2465/1490
3.1	Tyres			Polyurethane
3.2	Tyre size, front		mm	Φ343×140
3.3	Tyre size, rear		mm	Φ310×118
3.4	Additional wheels (castor wheels)		mm	Φ102×51
3.5	Wheels, number front/rear (x=drive wheels)			1x/2
3.7	Tread width, rear	b <sub>n</sub>	mm	1148
4.1	Tilt of mast/fork carriage forward/backward	α/β	°	2/4
4.3	Free lift	h	mm	2870
4.4	Lift	2	mm	9500

h

3

	SPECIFICATION	REF	UNIT	VALUE
4.5	Height, mast extended	$h_4$	T	10560
4.7	Height of overhead guard (cabin)	h	mm	2213
4.8	Seat height relating to SIP/stand height	6	mm	1076
4.1	Height of wheel arms	h	mm	333
4.19	Overall length	$l_1$	mm	2443
4.20	Length to face of forks	l2	mm	1373
4.21	Overall width	b1/b <sub>2</sub>	mm	1270
4.2	Fork dimensions	s/e/l	mm	40/120/1070
2	Fork carriage ISO 2328, class/type A, B			2A
4.2	Fork carriage width		mm	990
3	Distance between fork-arms	$b_5$	mm	240/770
4.2	Distance between wheel arms/loading surfaces			91
4.6	Ground clearance, laden, below mast		mm	5
4.3	Ground clearance, centre of wheelbase	$m_2$	mm	70
4.34.1	Aisle width for pallets 1000×1200 crossways	Ast	mm	2835
4.34.2	Aisle width for pallets 800 × 1200 lengthways	Ast	mm	2885
4.35	Turning radius	Wa	mm	1770
5.1	Travel speed, laden/unladen		km/	9/9.5
5.2	Lift speed, laden/unladen		h	0.45/0.55
5.3	Lowering speed, laden/unladen		m/s	0.5/0.45
5.8	Max. gradeability, laden/unladen		m/s	10/15
5.10	Service brake		%	Electromagnetic
6.1	Drive motor rating S2 60 min		kW	7
6.2	Lift motor rating at S3 15%		kW	20
6.4.1	Battery voltage		V	48
6.4.2	Battery nominal capacity K5		Ah	405
6.4.3	Battery type			Li-Ion
6.5	Battery weight		kg	490
8.1	Type of drive unit			AC
10.5	Steering design			Electronic
10.	Sound pressure level at the driver's seat		dB(A)	70
7	Charger output current		A	200

## 15.

Subject to modification of specifications and designs without prior notice as part of continuous product improvement. Images and technical data shown may include optional features and are provided for reference only. All dimensions are subject to standard manufacturing tolerances.

# RATED CAPACITIES GRAPH

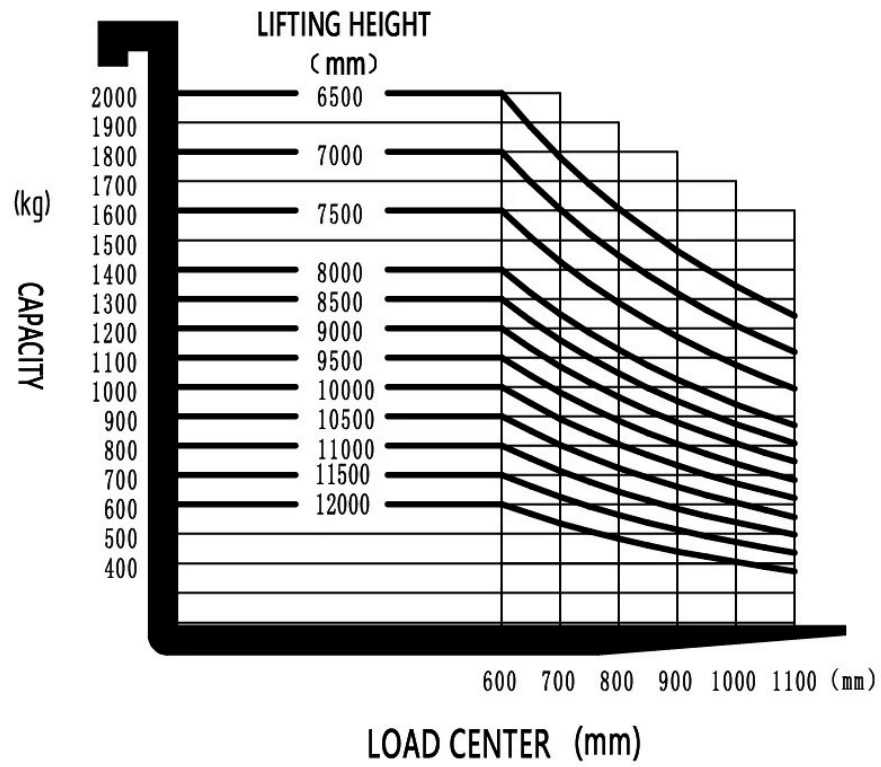

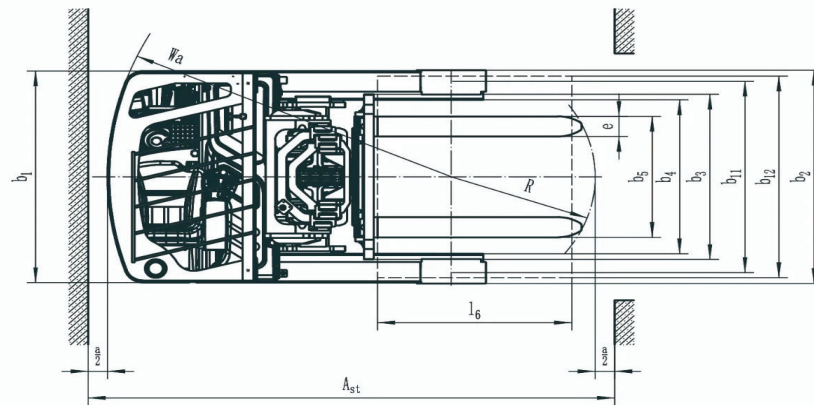
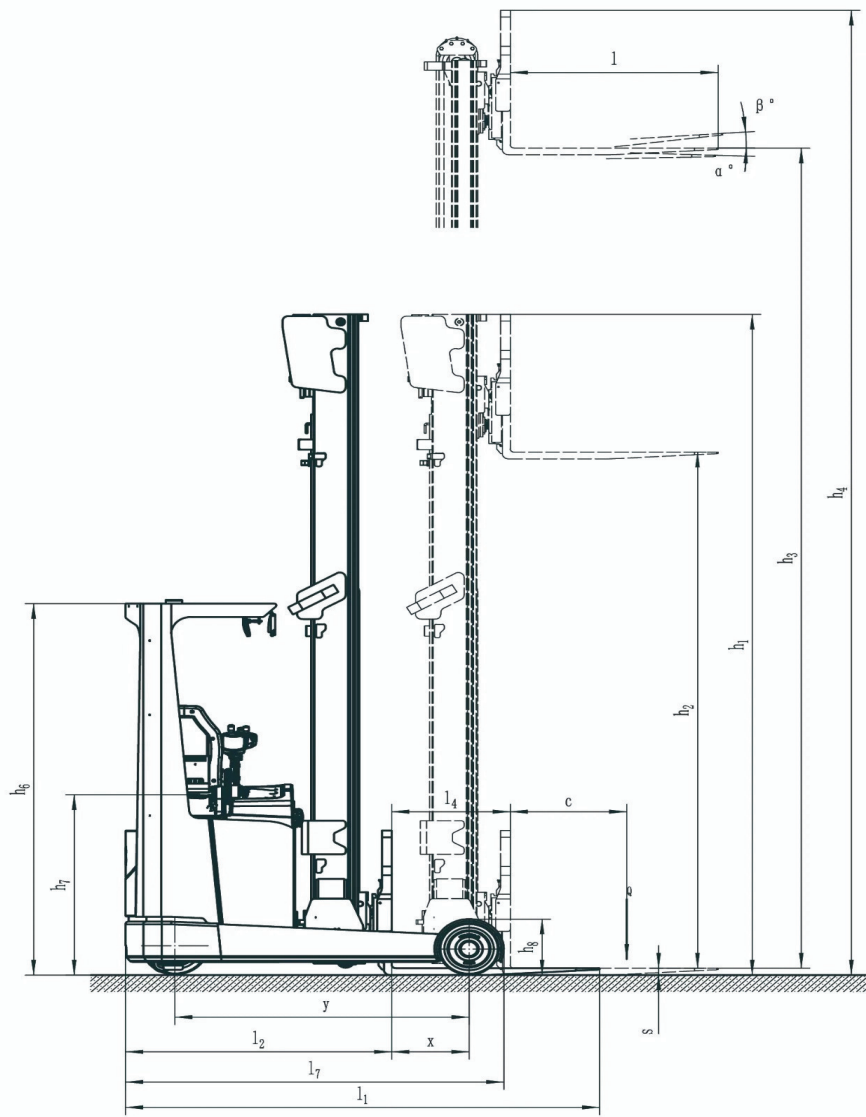

# Mast Options

MAST TYPE	LIFT HEIGHT (H3, MM)	MAST LOWERED HEIGHT (H1, MM)	MAST EXTENDED HEIGHT, NO BACKREST (H4, MM)	MAST EXTENDED HEIGHT, WITH BACKREST (H4, MM)	FREE LIFT HEIGHT, NO BACKREST (H2, MM)	FREE LIFT HEIGHT, WITH BACKREST (H2, MM)
3-Free Mast	4000	1965	4720	5060	1080	900
3-Free Mast	4500	2135	5220	5560	1260	1070
3-Free Mast	5000	2300	5720	6060	1420	1235
3-Free Mast	5500	2465	6220	6560	1580	1400
3-Free Mast	6000	2635	6720	7060	1760	1570
3-Free Mast	6500	2800	7220	7560	1920	1735
3-Free Mast	7000	3045	7720	8060	2160	1890
3-Free Mast	7500	3215	8220	8560	2340	2150
3-Free Mast	8000	3380	8720	9060	2500	2315
3-Free Mast	8500	3600	9220	9560	2720	2535
3-Free Mast	9000	3765	9720	10060	2880	2700
3-Free Mast	6955	3430	7640	7980	2554	2370
3-Free Mast	7255	3430	7940	8280	2554	2370
3-Free Mast	7555	3430	8240	8580	2554	2370
3-Free Mast	7955	3430	8640	8980	2554	2370
3-Free Mast	8255	3430	8940	9280	2554	2370
3-Free Mast	9655	3930	10340	10680	3054	2870
3-Free Mast	10000	4159	10715	11065	3268	2568
3-Free Mast	10500	4329	11215	11565	3428	2728
3-Free Mast	11000	4489	11715	12065	3608	2908
3-Free Mast	11500	4659	12215	12565	3768	3068
3-Free Mast	12000	4819	12715	13065	3948	3248

# Options

ITEM	OPTIONS (optional items marked in yellow)
Fork dimension	No   100*40*920   100*40*1150   100*40*1070   100*40*1370   100*40*1500   100*40*1600
Leg width	917
Fork carriage width option	770mm
Backrest height	1020mm
Load wheel type	Single
Load wheel material	PU
Drive wheel material	PU
Battery capacity	405Ah (Li-ion)   No
Charger	48V200A Li-ion External   48V150A Li-ion External
Seat type	Suspension + safety belt logic switch   Suspension with armrest + safety belt logic switch
Attachments	Built-in sideshifter
Electrostatic chain	NO   Yes and not customized
Castor wheels	Yes and not customized
Front lamp	LED
Rear lamp	No   LED
Warning lamp	Yes and not customized
Blue lamp	No   Yes and not customized
Area warning lamp	No   Yes and not customized
Buz zer	No   Yes and not customized
OPS system	Yes and not customized
Telematics	No   Yes and not customized
Cold storage	No   Yes and not customized
Forks tilt forward and backward	Yes and not customized
Overhead guard	Yes   Driver-in
AS/NZS function package	Yes and not customized
Turn speed control	Yes and not customized
Heating system during lithium battery charging	No   Yes and not customized
Operator identification device	No   Card reader   Fingerprint lock   Keypad with card reader
Drive assembly	ZK25